

IMPORTANT INFORMATION FOR OWNERS AND USERS OF ALL CONTAINERING DESIGN FRAME TANKS MANUFACTURED BY WELFIT ODDY

1. INTRODUCTION

- 1.1. During the period from 1986 to 1999, Welfit Oddy manufactured the Containereering design frame tank (the Tank) under licence from Containereering SARL of France.
- 1.2. Containereering made a number of design modifications to the frame of the Tank during this period. All design changes were submitted to and approved by the relevant certification authorities. Where necessary, prototype tests were carried out and all these models were fully certified by the relevant certification authorities.
- 1.3. During operation, Tanks built to the original design (Tanks built from Nov 86 to Jan 92) started developing fatigue cracks. These cracks started at the junction between the vacuum rings and the upper mount gusset. If these cracks continued to grow, they would propagate down the side wall of the ring and into the Tank shell. Welfit Oddy / Containereering therefore carried out a mount modification in the field on these Tanks during 1993. From the data we have, this modification has stood the test of time and has proved to be successful.
- 1.4. This was some 16 years ago. As a conscientious manufacturer, we have tried to monitor the condition and performance of all Tanks, and together with the latest design and software technology, are able to offer this update and recommendation.

2. UPDATE

- 2.1. Using FEA technology combined with field data collated in respect of operational impacts and fatigue , we advise that on all Containereering Tanks, the junction between the vacuum rings and the 4 mount gussets is the area of highest stress concentration and any crack initiation that could result in these areas, due to fatigue or abuse during the life of the tank, has the potential to propagate into the tank shell and result in leaks unless timeously repaired. The potential for these cracks to occur depends on many factors, such as:

- § The age of the Tank
- § The usage to which it has been subject to, both normal and abnormal use or abuse
- § The actual fatigue loads and cycles which it has been subject to
- § The maintenance of the Tank
- § Any accident damage to the Tank
- § The degree of corrosion / rusting of the mount gussets and vacuum ring

- 2.2. As you are aware, all steel fabrications have a limited life which is dependant on the mechanical properties of the steel and the operational use that it is subject to. Thermal stresses from heating, thinning due to corrosion and fatigue stress accumulation from service loads all contribute to the overall fatigue life. As is typical for most frame design tanks, on the assumption of an infinite life, the mount areas are likely to be the first to fail.
- 2.3. Based on the above and the fact that some of the Tanks are between 15 and 23 years old and may be reaching the end of their useable life (at least without repair), it is our view that **it would be prudent to increase the maintenance inspection in the mount areas of these Tanks with immediate effect.**

3. RECOMMENDATION

- 3.1. Because it is impossible to ascertain and verify the fatigue loadings that individual Tanks have been subject to over their lifespan to date, we recommend the following actions :
- 3.2. For tanks that are 15 years or older (Tanks built prior to Dec 94) , in addition to the statutory 2.5 and 5 year inspections, it is recommended that the 4 mount areas should be inspected as soon as possible, and should thereafter be subject to further regular annual inspections. Should the vacuum rings show any signs of fatigue cracking then these should be repaired.
- 3.3. For Tanks that are younger than 15 years (Tanks built from Jan 95 onwards), it is recommended that the 4 mount areas are inspected at each 2.5 and 5 year inspection. Should the vacuum rings show any signs of fatigue cracking then these should be repaired.
- 3.4. Specific areas to inspect within each of the 4 mount areas include (a) the junction of the vacuum ring and the top of the upper mount gusset, (b) the junction of the vacuum ring and bottom of the

lower mount gusset and (c) the junction of the barrel and the top of the 1st steam element cut out on the vacuum ring. This is shown graphically in Appendix A.

- 3.5. If you know or suspect that any Tanks may have been subject to any form of abuse, use outside the design parameters or certification requirements, impact or accidents, (or are unable to ascertain the position to your reasonable satisfaction) then these should be inspected irrespective of their age. Any such use will always dramatically affect the working life of a Tank. Specifically, we are aware of certain cases where there has been interference between the Tank bottom frame members and the road chassis used that results in vertical loads being transmitted into the Tank via such bottom frame members instead of through the corner castings and into the corner posts / end frame structure. In such cases, in all Tanks, if there is evidence of such interference of the Tank bottom frame members with a road or rail chassis, or if you suspect that there could have been such interference, then it is recommended that the 4 mount areas are inspected as soon as possible, irrespective of the age of the Tank.
- 3.6. If there are any Tanks that required the 1993 mount modification, but were not modified, then these should be located and, depending on their age and condition, either modified or withdrawn from service. At the time of the mount modification, lists of relevant tank numbers were sent to all owners. Whilst the majority of Tanks were modified, there were a few that could not be located. It was assumed that these Tanks had either been scrapped, lost or withdrawn from service. However, if any of these Tanks have been returned to service then they need to be identified. Owners were originally sent the details of such Tanks, as they were listed as part of the 1993 mount modification program, but if such details are not available in your records, we are able to supply such list.
- 3.7. Please find attached the recommended inspection procedure. (Appendix A). It is important to remove the insulation and clean the area prior to inspection. If in doubt about any cracking, then use a dye penetrant technique to verify if cracks are present.
- 3.8. There are various options available for repair, but these depend on the age and condition of each Tank, specifically the condition of the vacuum rings, mounts and general frame members, and should therefore be dealt with on an individual Tank basis. We are available to assist in this process if necessary. Ultimately, given the above, reframing / remanufacturing the Tanks is the best long term option, which has considerable other benefits. We are available to discuss this option.
4. **RESPONSIBILITY**
- 4.1. We are sure you have enjoyed good economic use from the Tanks over the years. By implementing the recommended actions we expect that you will be able to ensure the safety of the Tanks. If you do not follow the above advice we believe this will result in a serious risk of leaks.
- 4.2. However, whilst we provide this information based on further testing undertaken by us as a responsible manufacturer, we cannot guarantee the accuracy of the results or that such recommendations will prevent all potential risks.
- 4.3. All steel fabrications have a limited working life by nature, and as a result of the use and fatigue loadings, which we cannot monitor, this will vary from Tank to Tank. Therefore, whilst we suggest increased inspection should be implemented after 15 years, some Tanks will have a shorter (or longer) working life than this and we can provide no warranty regarding individual Tanks.
- 4.4. **We point out that responsibility to ensure use only in accordance with the design parameters and certification requirements and for ongoing inspection, maintenance, repairs and the safe working condition of all Tanks lies with the owner and/or user.**
- 4.5. Whilst we are taking all reasonable steps to provide this update to all customers and end users of the Tanks, given the age of the Tanks, our records will not be entirely complete or up to date. As such, we would ask that you provide copies of this notice to your own customers / lessees, other parties to whom you may have sold any of the Tanks, and other end users of the Tanks.

WELFIT ODDY (PTY) LIMITED

1 December 2009

APPENDIX A : MOUNT INSPECTION PROCEDURE

A) UPPER MOUNTS : On all 4 tank mounts, remove the upper cladding cover by drilling out the pop rivets. Cut the aluminium cladding with 2 parallel cuts approx 130 mm from the upper edge of the aperture – this will enable the cladding to be rolled / bent upwards to gain access for inspection. Remove any insulation in the area, and clean by means of wire brush

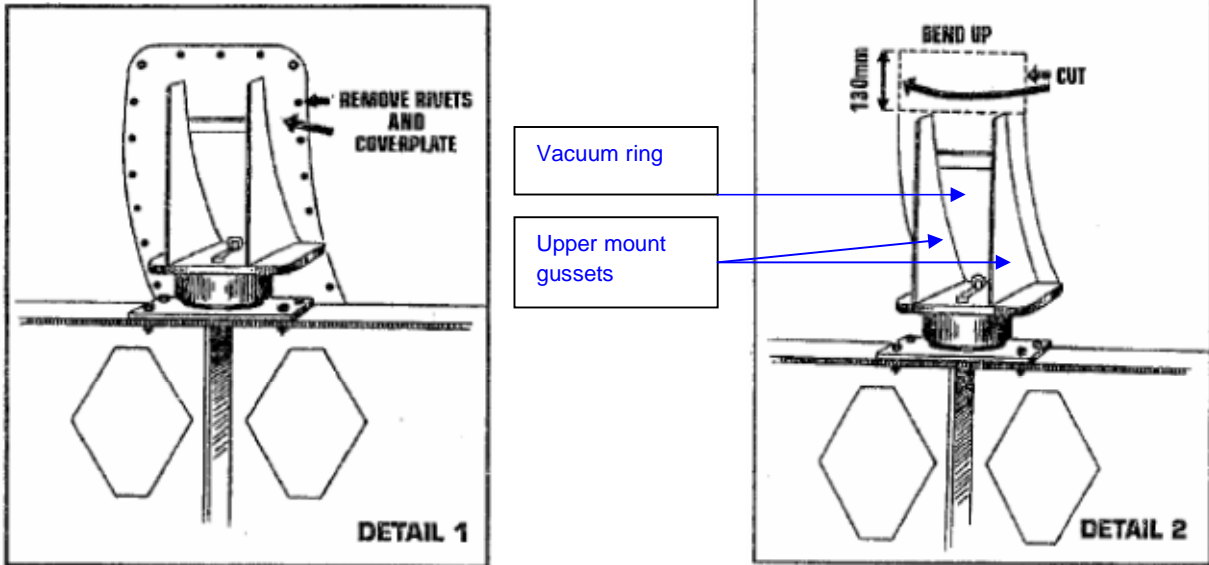

Upper mount inspection point : Inspect for cracks on the front and side wall of the vacuum ring at the top junction of the upper mount gusset and the vacuum ring, and on the tank vessel adjacent to this area

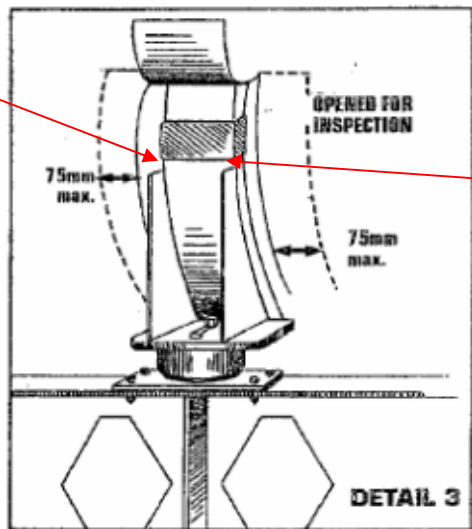

Upper mount inspection point : Inspect for cracks on the front and side wall of the vacuum ring at the top junction of the upper mount gusset and the vacuum ring, and on the tank vessel adjacent to this area

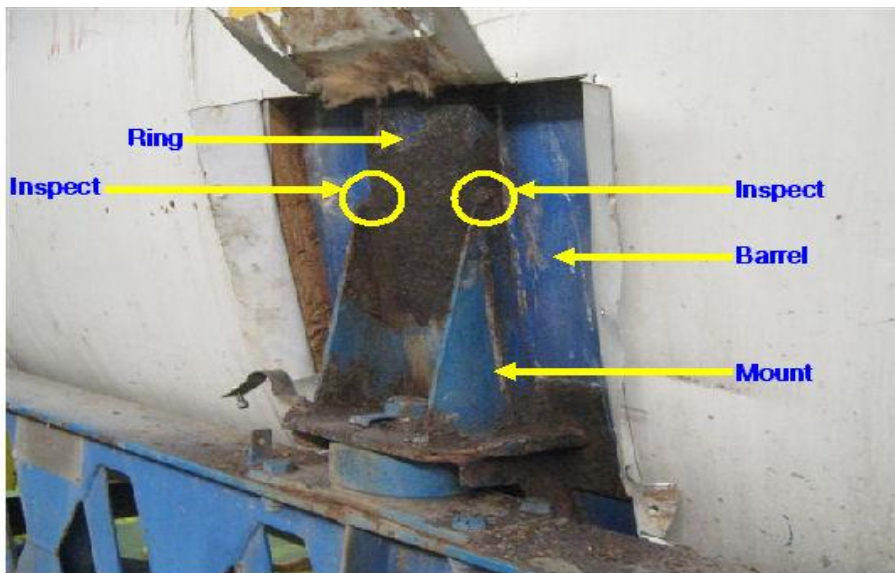

B) LOWER MOUNTS and C) TOP OF THE FIRST STEAM CUT-OUT : The inspection procedure for these areas is a mirror image of that for each of the top mounts.

Remove the cladding panel and insulation , and clean by means of wire brush :

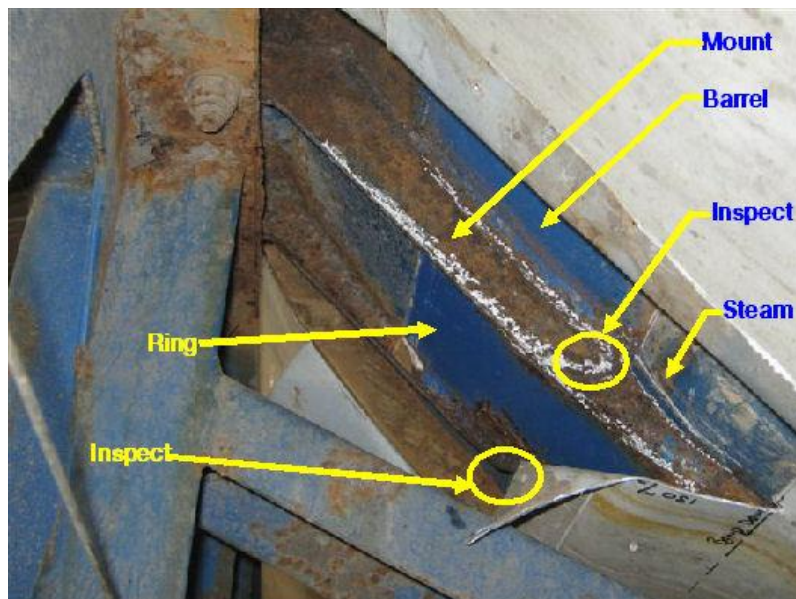
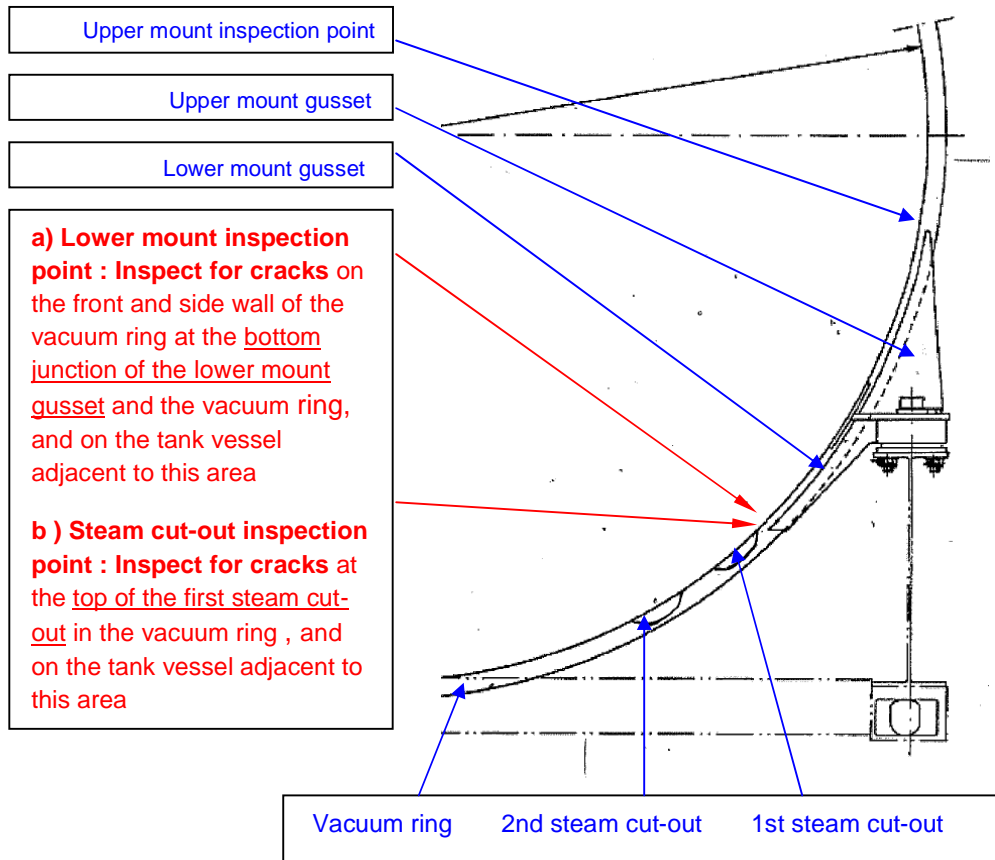

After inspection and any repairs, clean / wire brush the area in preparation for painting. Apply primer using a rust inhibiting primer such as a zinc rich epoxy. Apply top coat in matching colour using an acrylic paint. Reinsulate using mineral wool. Roll down cladding and rivet the cladding cover plates back into position. Re-seal all joints